

### INSTRUCTIONS FOR INSTALLATION OF SINGLE OR DOUBLE CYLINDER DEADBOLTS AND THE REPLACEMENT OF EXISTING LOCKS

FOR USE ON DOOR THICK 1-3/8" TO 1-3/4" (35mm-45mm)

TOOLS REQUIRED FOR NEW CONSTRUCTION:

1 philips head screwdriver

1 1-3/8" (35mm) hole saw

1 1" (25mm) drill & 1 chisel

TOOLS REQUIRED FOR REPLACEMENT:

1 philips head screwdriver

#### 1. MARK DOOR

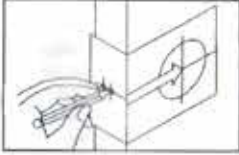

- Fold and apply template on high edge of door bevel and mark center of door edge as indicated on template at the desired height from the floor.
- Mark center hole on door face through guide on template for either 2-3/8" or 2-3/4" (60mm or 70mm) backset.

NOTE: BACKSET ON DOOR FACE MUST BE SAME AS BACKSET OF YOUR LOCK.

#### 2. DRILL HOLES



1" (25mm)  
FOR DEADBOLT

1-3/8" (35mm) HOLE  
FOR LOCKSET

Drill holes as marked.

NOTE:  
DRILL 1-3/8" (35mm)  
HOLE FROM BOTH  
SIDES OF DOOR TO AVOID  
SPLITTING WOOD.

#### 3. INSTALL LATCH

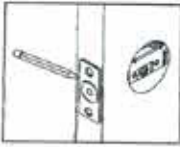

Insert latch in hole. Mark outline of face plate and remove latch.

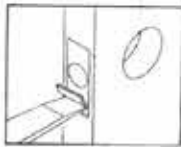

Chisel 1/8" (3mm) deep or until face plate flush with door edge.

1 1/8" X 2 1/4"

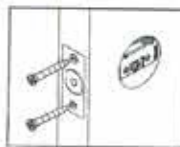

Insert latch and tighten screws.

#### 4. INSTALL STRIKE



Close door to mark horizontal center line of strike.



Measure one half of door thickness from door stop and mark vertical center line of strike. Drill 1" (25mm) hole 1" (25mm) deep at intersection of horizontal and vertical center line of strike. Match

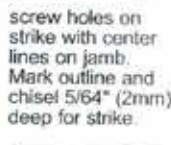

screw holes on strike with center lines on jamb. Mark outline and chisel 5/64" (2mm) deep for strike.  
Install strike and tighten screws.

#### 5. INSTALL SINGLE CYLINDER

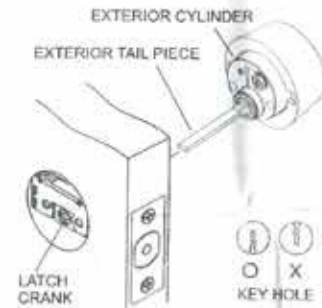

- Retract deadbolt to unlock position.
- Insert exterior tail piece horizontally through latch crank.
- Press exterior cylinder flush against door.
- Install inside turn unit and tighten installation screws.

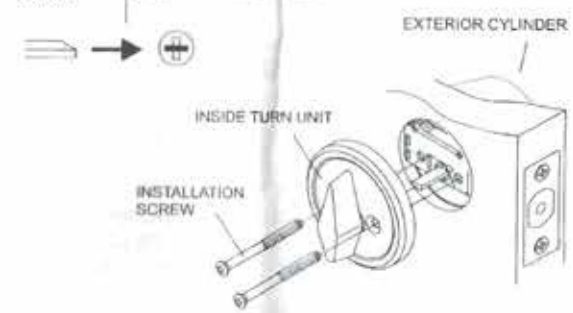

#### 6. INSTALL DOUBLE CYLINDER

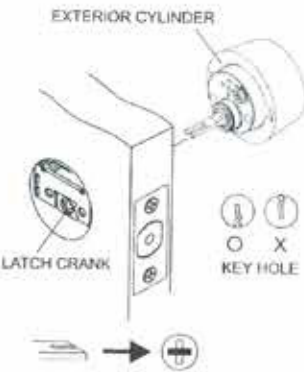

- Retract deadbolt to unlock position.
- Insert exterior tail piece horizontally through latch crank.
- Press exterior cylinder flush against door.
- Insert interior tail piece vertically through latch crank.
- Press interior cylinder flush against door and tighten installation screws.

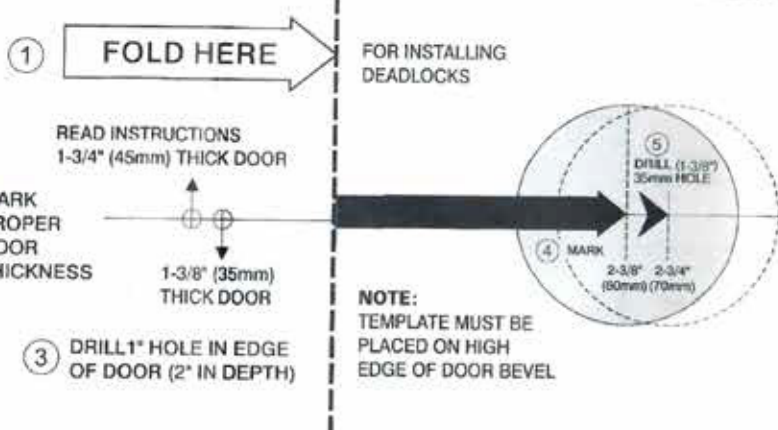
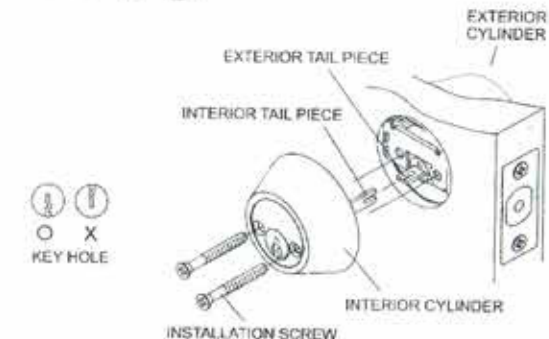

Not to Scale

The use of non-clutching impact drivers to install this hardware will automatically void the warranty.